

(12) STANDARD PATENT
(19) AUSTRALIAN PATENT OFFICE

(11) Application No. **AU 2003226330 B2**

(54) Title
Nozzle for jet drilling and associated method

(51) International Patent Classification(s)
E21B 7/08 (2006.01) **E21B 7/18** (2006.01)

(21) Application No: **2003226330** (22) Date of Filing: **2003.04.09**

(87) WIPO No: **WO03/087522**

(30) Priority Data

(31) Number	(32) Date	(33) Country
10/119,790	2002.04.10	US

(43) Publication Date: **2003.10.27**

(43) Publication Journal Date: **2003.12.04**

(44) Accepted Journal Date: **2007.05.31**

(71) Applicant(s)
Buckman Jet Drilling, Inc.

(72) Inventor(s)
Dotson, Thomas, L.;Bell, Wendell, S.;Buckman, William, G., Sr.;McDaniels, Michael, D.

(74) Agent / Attorney
Griffith Hack, Level 29, Northpoint 100 Miller Street, North Sydney, NSW, 2060

(56) Related Art
US 4787465 A
US 6293984 B1
US 5862871 A
US 5853056 A

(12) INTERNATIONAL APPLICATION PUBLISHED UNDER THE PATENT COOPERATION TREATY (PCT)

(19) World Intellectual Property
Organization
International Bureau



(43) International Publication Date
23 October 2003 (23.10.2003)

PCT

(10) International Publication Number
WO 2003/087522 A3

- (51) International Patent Classification⁷: **E21B 07/18**,
07/08
- (21) International Application Number:
PCT/US2003/010813
- (22) International Filing Date: 9 April 2003 (09.04.2003)
- (25) Filing Language: English
- (26) Publication Language: English
- (30) Priority Data:
10/119,790 10 April 2002 (10.04.2002) US
- (71) Applicant (for all designated States except US): **BUCKMAN JET DRILLING, INC.** [US/US]; 183 St. Charles Avenue, Bowling Green, KY 42101 (US).

CZ, DE, DK, DM, DZ, EC, EE, ES, FI, GB, GD, GE, GH, GM, HR, HU, ID, IL, IN, IS, JP, KE, KG, KP, KR, KZ, LC, LK, LR, LS, LT, LU, LV, MA, MD, MG, MK, MN, MW, MX, MZ, NO, NZ, OM, PH, PL, PT, RO, RU, SC, SD, SE, SG, SK, SL, TJ, TM, TN, TR, TT, TZ, UA, UG, US, UZ, VC, VN, YU, ZA, ZM, ZW.

- (84) Designated States (regional): ARIPO patent (GH, GM, KE, LS, MW, MZ, SD, SL, SZ, TZ, UG, ZM, ZW), Eurasian patent (AM, AZ, BY, KG, KZ, MD, RU, TJ, TM), European patent (AT, BE, BG, CH, CY, CZ, DE, DK, EE, ES, FI, FR, GB, GR, HU, IE, IT, LU, MC, NL, PT, RO, SE, SI, SK, TR), OAPI patent (BF, BJ, CF, CG, CI, CM, GA, GN, GQ, GW, ML, MR, NE, SN, TD, TG).

Declarations under Rule 4.17:

— as to applicant's entitlement to apply for and be granted a patent (Rule 4.17(ii)) for the following designations AE, AG, AL, AM, AT, AU, AZ, BA, BB, BG, BR, BY, BZ, CA, CH, CN, CO, CR, CU, CZ, DE, DK, DM, DZ, EC, EE, ES, FI, GB, GD, GE, GI, GM, HR, HU, ID, IL, IN, IS, JP, KE, KG, KP, KR, KZ, LC, LK, LR, LS, LT, LU, LV, MA, MD, MG, MK, MN, MW, MX, MZ, NO, NZ, OM, PH, PL, PT, RO, RU, SC, SD, SE, SG, SK, SL, TJ, TM, TN, TR, TT, TZ, UA, UG, UZ, VC, VN, YU, ZA, ZM, ZW, ARIPO patent (GH, GM, KE, LS, MW, MZ, SD, SI, SZ, TZ, UG, ZM, ZW), Eurasian patent (AM, AZ, BY, KG, KZ, MD, RU, TJ, TM), European patent (AT, BE, BG, CH, CY, CZ, DE, DK, EE, ES, FI, FR, GB, GR, HU, IE, IT, LU, MC, NL, PT, RO, SE, SI, SK, TR), OAPI patent (BF, BJ, CF, CG, CI, CM, GA, GN, GQ, GW, ML, MR, NE, SN, TD, TG)

[Continued on next page]

- (72) Inventors; and
- (75) Inventors/Applicants (for US only): **BUCKMAN, William, G., Sr.** [US/US]; 504 Memphis Junction Road, Bowling Green, KY 42101 (US). **DOTSON, Thomas, L.** [US/US]; 2729 Smallhouse Road, Bowling Green, KY 42104 (US). **MCDANIELS, Michael, D.** [US/US]; 3061 South Fork Road, Glasgow, KY 42141 (US). **BELL, Wendell, S.** [US/US]; 7675 Edmonton Road, Glasgow, KY 42141 (US).
- (74) Agent: **COOKE, Claude, E., Jr.**; Baker Botts L.L.P., One Shell Plaza, 910 Louisiana, Houston, TX 77002-4995 (US).
- (81) Designated States (national): AE, AG, AL, AM, AT, AU, AZ, BA, BB, BG, BR, BY, BZ, CA, CH, CN, CO, CR, CU,

(54) Title: NOZZLE FOR JET DRILLING AND ASSOCIATED METHOD

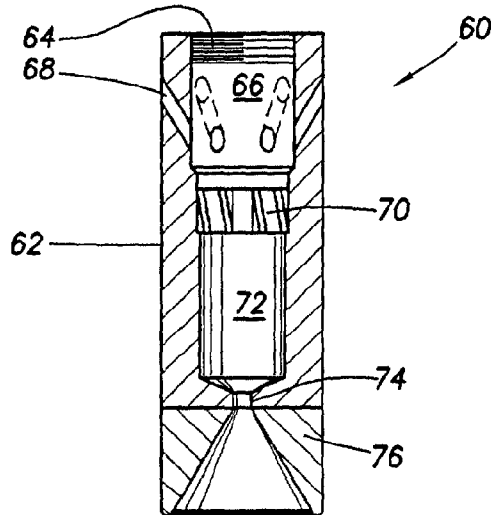

(57) Abstract: A jet nozzle (60) is provided for drilling holes through the earth. The nozzle (60) may include orifices (68) for discharging fluid to drive the nozzle forward and includes a disk (70) or other device having orifices (80) to produce a swirling motion to fluid in the body of the nozzle. Swirling fluid is discharged from a front orifice (74) and an extension (76) is placed forward of the front orifice to confine the swirling fluid in a radial direction.

WO 2003/087522 A3